

### TOOLS REQUIRED:

- 7/16" open-end ratcheting wrench
- 9/16" open-end ratcheting wrench
- 3/16 x 12" drill bit
- 1/8 x 6" drill bit
- 12" crescent wrench
- 1/2" open-end ratcheting wrench
- 18 or 24 volt cordless drill
- 1/2" socket driver with extension
- measuring tape
- string line
- utility knife (hooked blade)
- hammer
- hive tool

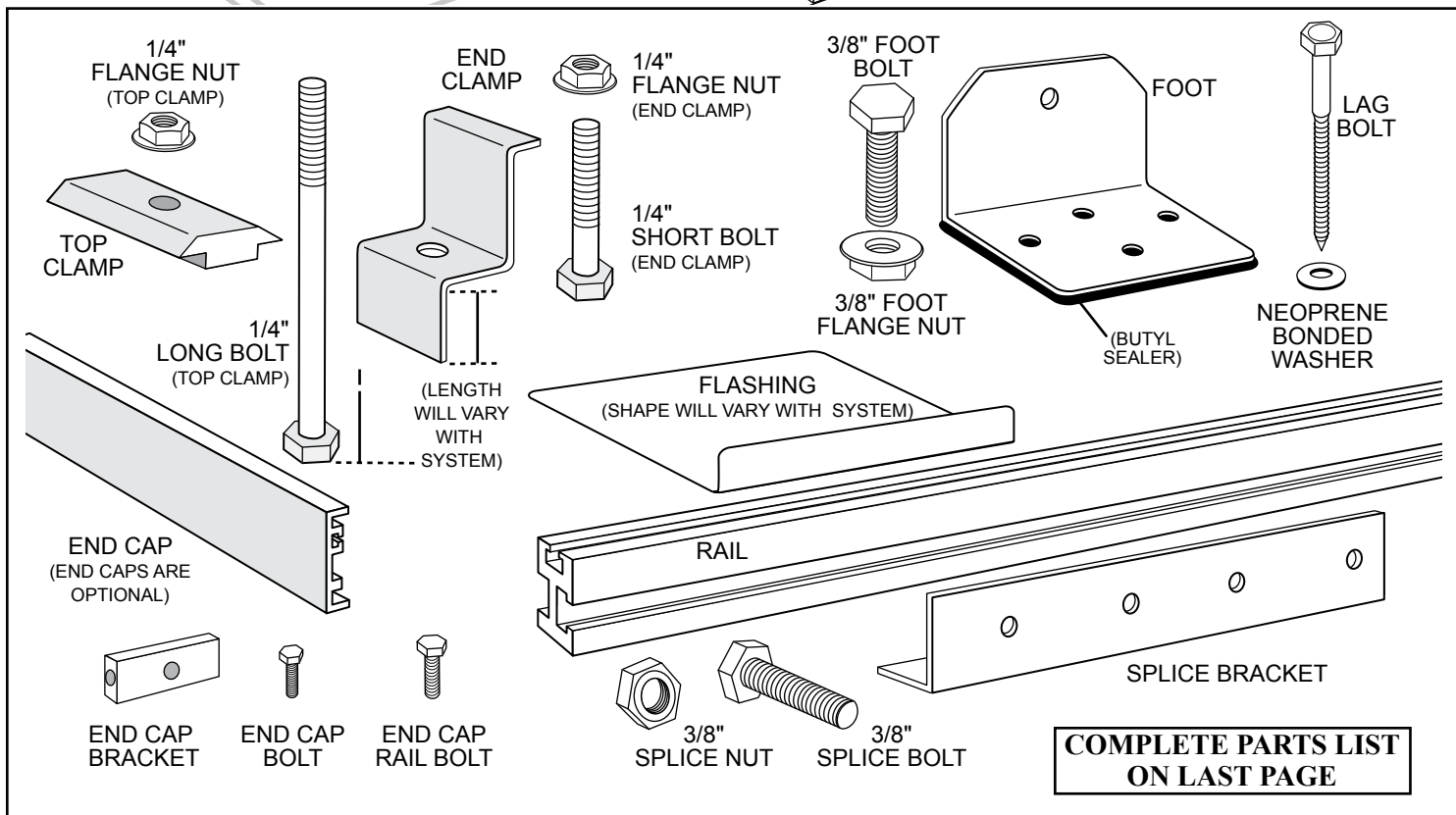

**COMPLETE PARTS LIST  
ON LAST PAGE**

**FOR A SINGLE ROW OF MODULES:**

**1** **Position 4 end feet for rails.**  
**Remaining feet will be added later.**

- First two support feet must be no more than 6' apart.
- Modules must not extend beyond 32" from the end feet.

32" MAXIMUM MODULE OVERHANG      6' MAXIMUM DISTANCE BETWEEN END FEET

(FIRST TWO SUPPORT FEET)

**2** **Locate the center of the rafters by finding the edges:**

- Measure inside the attic from a reference point such as a vent pipe or sky light to the rafter.
- Note this distance; note the width of the rafters.
- Mark rafter location on roof shingles.
- Add the width of the rafter and make another mark on the shingle.

*Midpoint of the two marks will be the center of the foot placement.*

**NO ACCESS TO ATTIC:**  
**Use an 1/8" drill bit to probe for the rafter edges.**

- Place a foot on a shingle row over the rafter.
- Make a probe hole centered on the foot with an 1/8" drill bit. From there, find the rafter edges, and mark the center. (The probe holes need to be covered by the foot so that the butyl compound can seal the probe holes.)
- NOTE: If the bit misses the rafter while probing, if possible, access the attic, find the drill bit and determine the amount of correction.

**The down side of the rafters can be located if the rafters are visible in the overhang. Use caution; the overhang rafters may only be attached to the sides of the true rafters.**

**! RAFTERS ARE NOT ALWAYS STRAIGHT—**  
**Probing for the edges of each rafter to find the center point is required for correct foot installation.**

**3** **POSITION FIRST END FOOT ON RAFTER.**

- Remove any extra shingle or decorative material where the feet align with the rafter.
- Using a flat bar (hive tool) lift the shingle above the row where the foot will be attached.
- Slide the Solar Racks flashing under the lifted shingle, centering it on the two edge marks.
- **DO NOT TO PEEL THE ADHESIVE BACKING FROM THE FOOT YET.**

(VERTICAL INSTALLATION)

**4** **SHINGLE ALIGNMENT**

Check to see if the shingle row is aligned. If not, the end feet can be placed lower down on the shingle in order for the inner feet to be aligned correctly.

**5** **AT THE CENTER POINT OF THE RAFTER MARKS:**

- Pre-drill the 2 lag holes to 3-1/2" using a 3/16 x 12" drill bit.
- Peel the adhesive backing from the foot.
- Insert lag bolts with sealing washers.
- Torque bolts to approximately 15 ft/lbs.
- Tighten till the butyl compound just starts to seep slightly from under the foot.

(VERTICAL INSTALLATION)

## 6 INSTALL SECOND END FOOT.

- Use a chalk/string line across the shingle row to the second end foot location.
- This will provide a straight edge to line up the interior feet.
- Align second foot to first end foot. Use a crescent wrench to change the angle slightly if necessary.

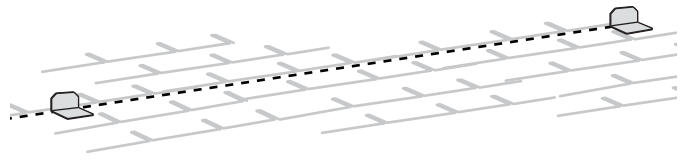

## 7 REPEAT INSTALLATION FOR EACH OF THE INTERIOR FEET.

- Flashing • Pre-drill • Align • Tighten

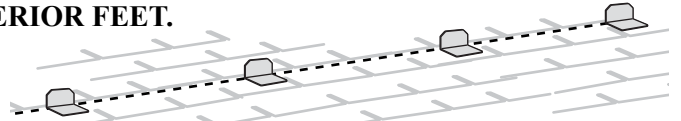

## 8 ATTACH RAIL TO FEET ON UPPER SECTION:

- Position first rail above the row of feet with the top slot up, side slot to feet.
- Slide 3/8" bolts into the side slot, one for each foot.
- Align the bolts to the upper hole on the foot plate.
- Make sure the cantilever distance on the ends is less than the maximum amount allowed 30".
- Attach the correct flange nuts and tighten.

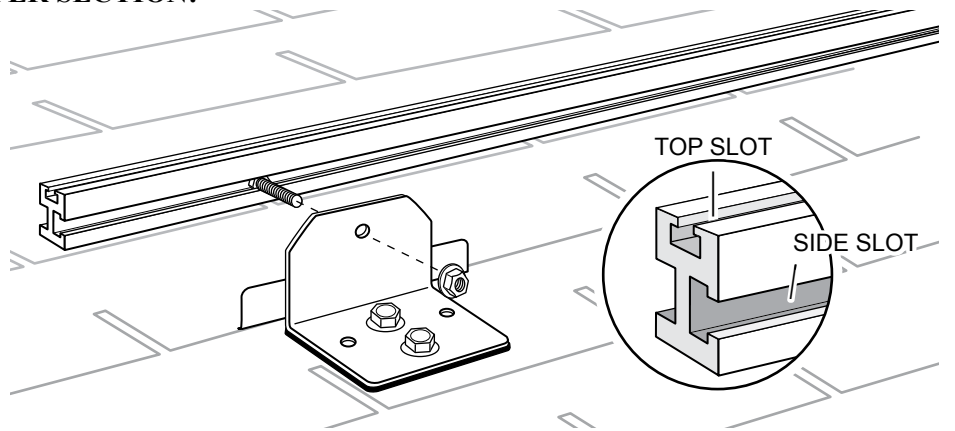

## 9 ATTACH RAIL TO FEET ON DOWNSIDE SECTION:

- Position rails equal distance from the roof edge.
- Use a string line to keep the ends aligned.
- Slide 3/8" bolts, into rail, align to feet, attach flange nut.

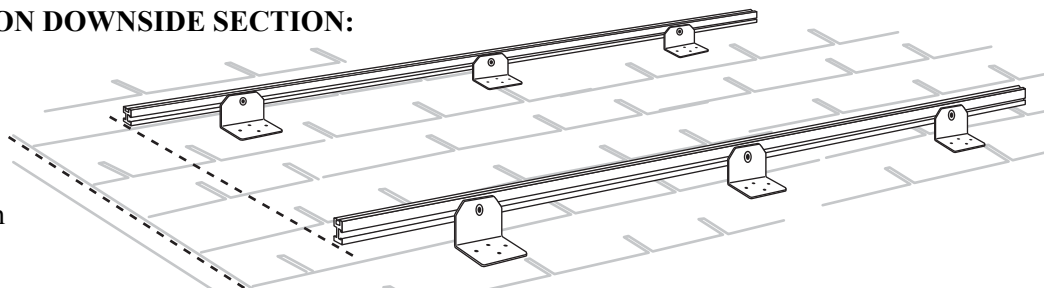

## 10 SPLICE KIT IS REQUIRED TO COMBINE LENGTHS OF RAIL:

Splice Kit includes

- 2 brackets
- 8 bolts
- 8 washers

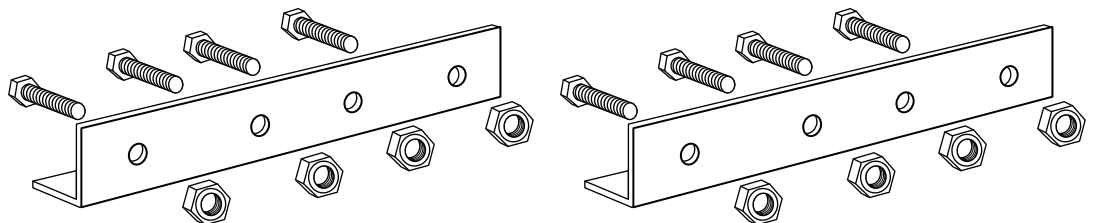

## 11 Slide four 3/8" bolts into the side slot.

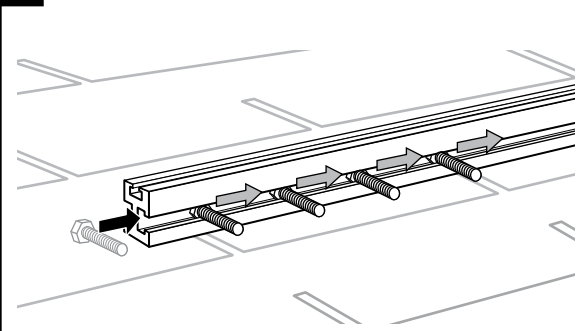

- ## 12
- Align the bolts, two on each side of a rail join.
  - Position splice bracket as shown.
  - Attach the splice nuts and tighten.

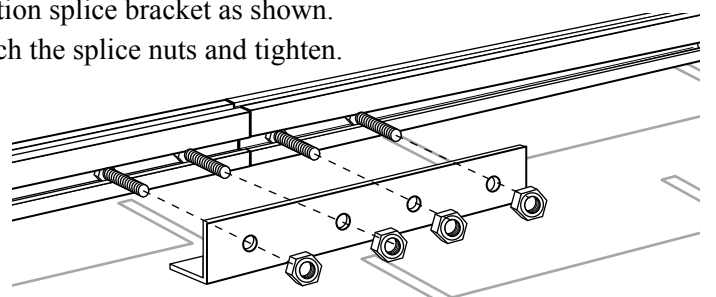

**13 TOP CLAMPS ASSEMBLIES:**

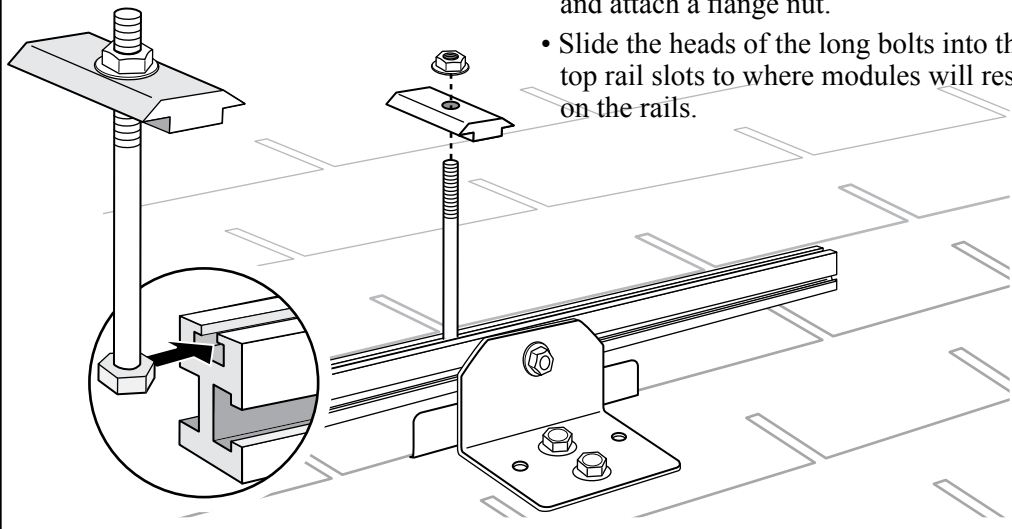

- Insert long bolt through the top clamp and attach a flange nut.
- Slide the heads of the long bolts into the top rail slots to where modules will rest on the rails.

**14 END CLAMP ASSEMBLIES:**

Insert short bolt through the end clamp and attach a flange nut on the bolt.

*Set these aside.*

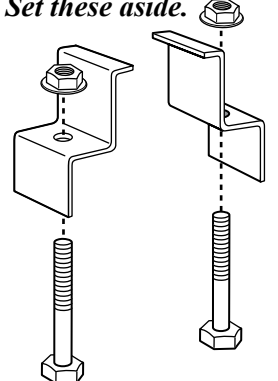

**15 INSTALL FIRST END MODULE:**

- Place the first module 1-1/4" from the end of the two rails.
- Slide each end clamp assembly into the rail ends until flush with the side of the module.
- Tighten end clamps.

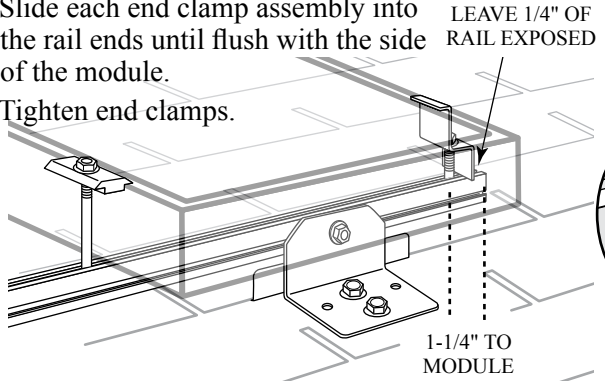

LEAVE 1/4" OF RAIL EXPOSED

1-1/4" TO MODULE

**16 INSTALL OTHER END MODULE:**

- Repeat installation at the opposite end of the rails with a second module.
- Before placing the interior modules make sure the two end modules are the same distance from the roof line or ridge cap. (Make a string line across the top of the modules to align.)
- Loosen end clamps and realign if necessary.

**17 INSTALL INTERIOR MODULES:**

- Align top clamps to edge of module.
- Position third module to align with first and second.
- Tighten top clamps.
- Repeat until all modules are in place.
- Tighten all clamps as needed.

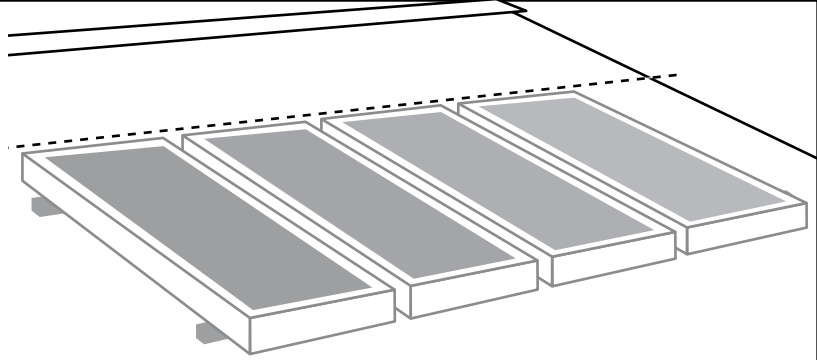
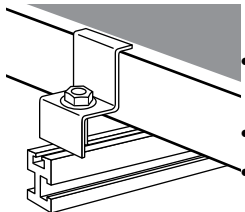

**Optional End Caps Installation —**

**18 ATTACH END CAPS:**

- Insert small cover bolt head into end cap clamp.
- Tighten.
- Install clamp bolt into clamp, do not tighten.

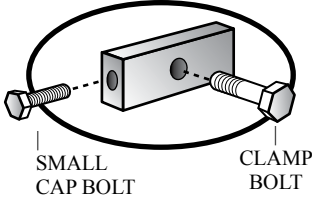

SMALL CAP BOLT CLAMP BOLT

**19**

- Slide small bolt head into end cap slot.
- Insert end cap clamp into rail ends.
- TIGHTEN CLAMP BOLTS.

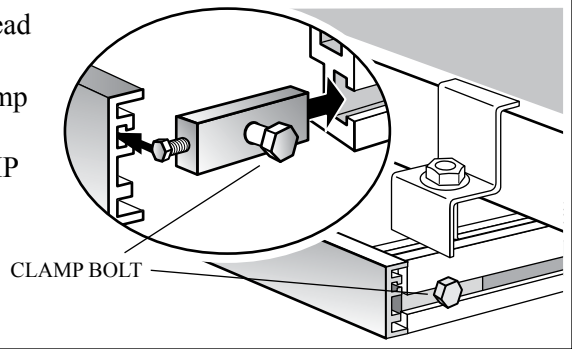

CLAMP BOLT



## IMPORTANT WARNING

It is critical that Solar Racks be properly and securely attached to the roof of a house. Improper attachment could result in damage to the house, roof or solar modules.

You are responsible for securing the racks properly and checking the attachments prior to module installation. Read and understand all of the instructions and cautions supplied

with your Solar Rack product prior to installation or use.

If you do not understand all of the instructions and cautions, or if you have no mechanical experience and are not thoroughly familiar with the installation procedures, you should have the product installed by a professional installer such as a qualified licensed contractor.

**CALL OR WRITE FOR REPLACEMENT PARTS OR FOR OPTIONAL ATTACHMENTS.**

**SOLAR RACKS, LLC**

**901 "O" STREET • ARCATA, CA 95521 • (707) 826-9214**

### REPLACEMENT PARTS

---

CE-151.8      END CLAMP

---

CE-151.65      END CLAMP

---

CE-151.4      END CLAMP

---

HW-0202      1/4-20 X 1 HX HD CAP BOLT

---

HW-0207      1/4-20 X 3/4 HX HD CAP BOLT

---

CT-0515      TOP CLAMP

---

HW-0204      1/4 X 2 HX HD CAP BOLT

---

HW-0206      1/4 X 2-1/4 HX HD CAP BOLT

---

HW-0203      1/4 X 2-1/2 HX HD CAP BOLT

---

HW-0201      1/4-20 SERRATED FLANGE NUT

---

FB-0355      3-1/2" FOOT WITH BUTYL

---

FL-0607      FLASHING (7" PC)

---

HW-0101      3/8-16 X 1 HX HD CAP BOLT

---

HW-0102      3/8-16 SERRATED FLANGE NUT

---

HW-0301      5/16 X 3-1/2 LAG SCREW

---

HW-0302      5/16 WASHER EPDM

---

RE-0114      RAIL EXTRUSION (TOTAL INCHES)

---

SK-0159      SPLICE KIT (1 KIT WILL JOIN 2 RAIL EXTRUSIONS)

---

HW-0103      3/8-16 X 3/4 HEX HD CAP BOLT

---

# SOLAR RACKS, LLC – LIMITED WARRANTY

---

- ***What Does This Warranty Cover?***

This warranty covers any defects in your new Solar Racks product.

- ***How Long Does The Coverage Last?***

This warranty lasts as long as you own your Solar Racks product. Coverage terminates if you sell or otherwise transfer the product.

- ***What Will Solar Racks Do?***

At its option, and subject to the limitations described herein, Solar Racks will: (i) repair or replace any defective product at no charge; (ii) refund the full purchase price of the product; or (iii) issue credit in the amount of the purchase price to be used toward the purchase of new Solar Racks purchases or accessories.

- ***What Does This Warranty Not Cover?***

The following are not covered by this warranty: any problem that is caused by abuse; normal wear and tear; defective roofing; modifications or repairs not performed or authorized by Solar Racks; overloading; misuse, including but not limited to failure to assemble, mount, or use the product in accordance with its written instructions or guidelines included with the product or made available to the original purchaser; or an act of God (such as wind storms or similar events). No warranty is given for Solar Racks products purchased or used outside the United States, Canada, or Mexico. To the furthest extent permitted by law, (i) this warranty does not cover damage to property other than the product itself; and (ii) the remedies provided for herein shall be exclusive.

SOLAR RACKS LIMITS THE DURATION OF ALL IMPLIED WARRANTIES, INCLUDING BUT NOT LIMITED TO ANY WARRANTY OF MERCHANTABILITY OR FITNESS FOR A PARTICULAR PURPOSE TO THE SHORTEST PERIOD PERMITTED BY LAW, WHICH IN ANY EVENT SHALL NOT EXCEED THE DURATION OF THIS WARRANTY. Some states do not allow limitations on how long an implied warranty lasts, so the above limitation may not apply to you. ALSO, CONSEQUENTIAL AND INCIDENTAL DAMAGES ARE NOT RECOVERABLE UNDER THIS WARRANTY. Some states do not allow the exclusion or limitation of incidental or consequential damages, so the above limitation or exclusion may not apply.

- ***How Do You Get Service?***

In order to be eligible for service under this warranty you must immediately notify Solar Racks upon learning of any defect of its products by either calling the phone number listed below or writing to the address listed below and explaining the nature of the defect. If appropriate, arrangements for service under this warranty will be made. You may be required to provide proof of purchase prior to obtaining service under this warranty. In addition, Solar Racks may require you to return the product to Solar Racks at your sole cost and expense for service and/or a determination by Solar Racks, in its sole discretion, as to whether the product is defective.

Solar Racks, LLC  
901 "O" Street, Suite E  
Arcata, CA 95521  
(707) 826-9214

- ***How Does State Law Apply?***

This warranty gives you specific legal rights, and you may also have other rights which vary from state to state.



## Solar Racks

901 "O" STREET • ARCATA, CA 95521 • (707) 826-9214